

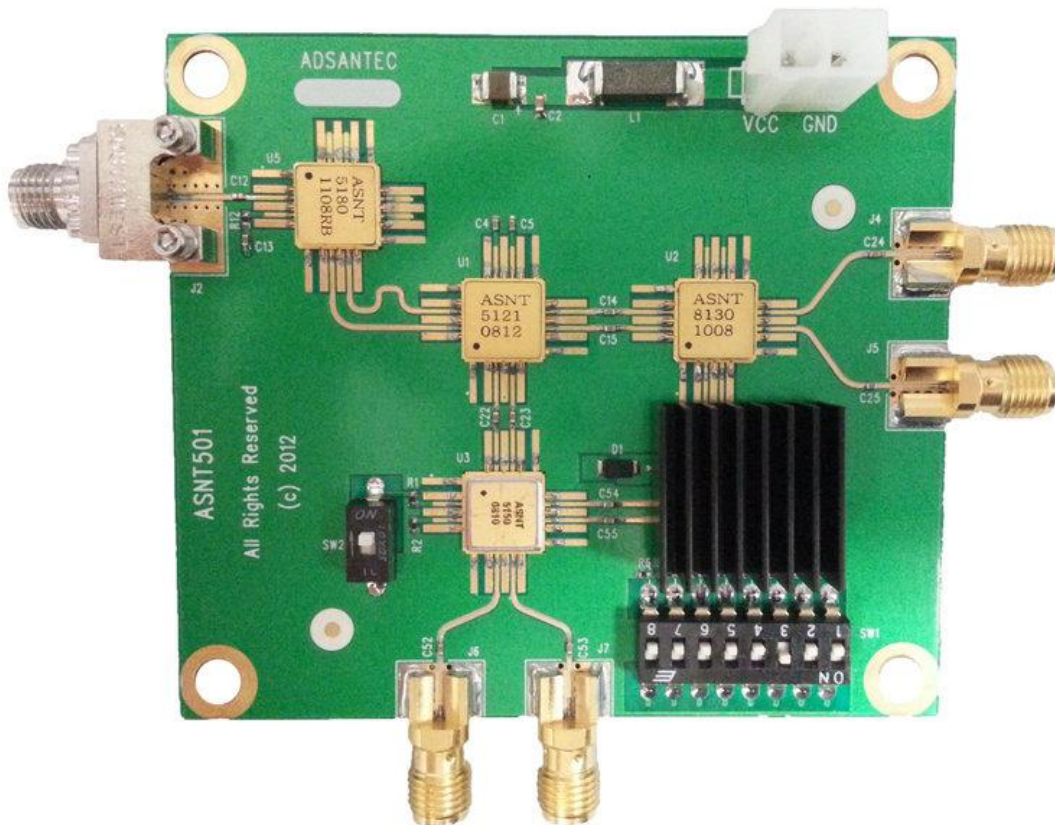

ASNT_501 2kHz-41GHz Clock Divide-by-8/2-to-1024

- Broadband frequency range from 2kHz – 41GHz
- Minimal insertion jitter
- Fast rise/fall times
- 50% duty cycle for all divide ratios
- Selectable divide output up to 1024
- Second divide by 8 output
- Positive +3.3V supply





DESCRIPTION

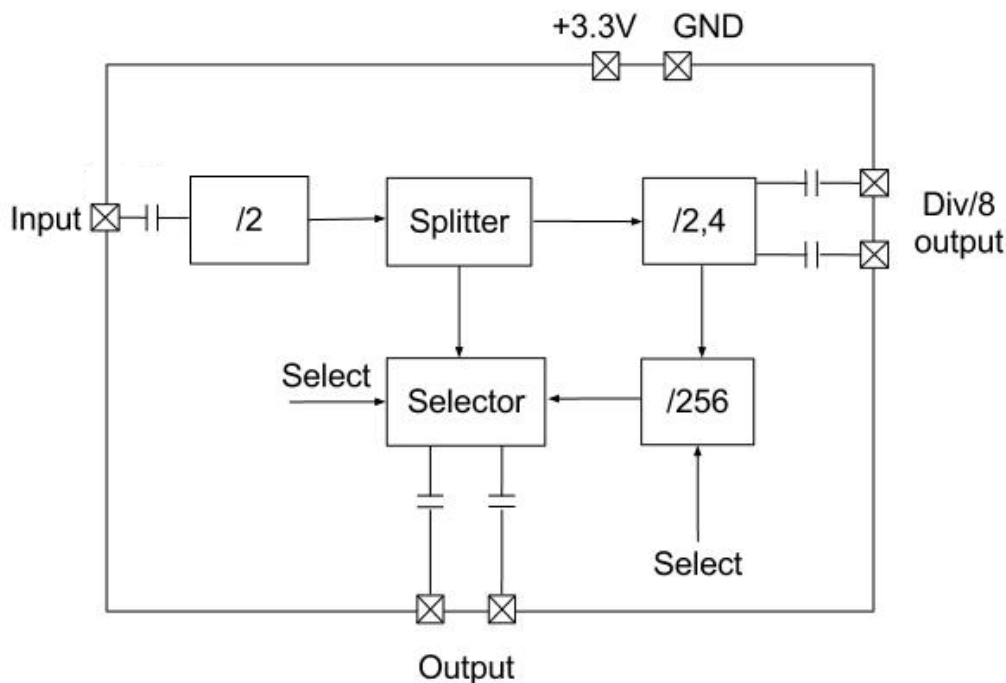

Fig. 1 Functional Block Diagram

The ASNT_501 system on board functions as a multi-purpose divider for test, microwave, and communication applications. The selectable divide output can be operated single-ended or differentially. A secondary fixed **divide-by-8** output can also be used single-ended or differentially. The high-speed clock input is AC coupled with a K-type Southwest connector MFG PN: 1092-03A-5. The clock outputs are AC coupled with Emerson SMA connectors MFG PN: 142-0761-881. Power is supplied through a two pin MOLEX connector P/N: 39-28-1023.

APPLICATIONS

The ASNT_501 divider can be used as a prescaler to extend the useful frequency range for triggering. The second fixed **divide-by-8** output can be used to synchronize other devices. The divider can also be used as a prescaler for PLL's or frequency counters.



DIVIDE RATIO CONTROL

The divide by (2-to-1024) output has been configured to divide the input frequency ratio from 2 to 1024. The following equation {Div/ output n = 4m}, where m is an integer from 1 to 256 which provides all possible divide ratios. The divide ratio control contains 8 switches which represent 8 bits. The LSB starts at SW1 and the MSB ends at SW8. The binary value of zero gives a decimal m value of 256. Ascending binary values increase the decimal value m. [Table 1](#) shows values of m with their corresponding binary representation.

Table 1. Binary Values for Divide Ratio

DIP SW #	m	n
8 7 6 5 4 3 2 1	Switch Ratio	Divide Ratio
0 0 0 0 0 0 1	1	4
0 0 0 0 0 1 0	2	8
0 0 0 0 0 1 1	3	12
0 0 0 0 1 0 0	4	16
...		
0 0 0 1 1 0 0 1	25	100
.		
.		
.		
1 1 1 1 1 0 1 0	250	1000
...		
1 1 1 1 1 1 1 1	255	1020
0 0 0 0 0 0 0 0	256	1024

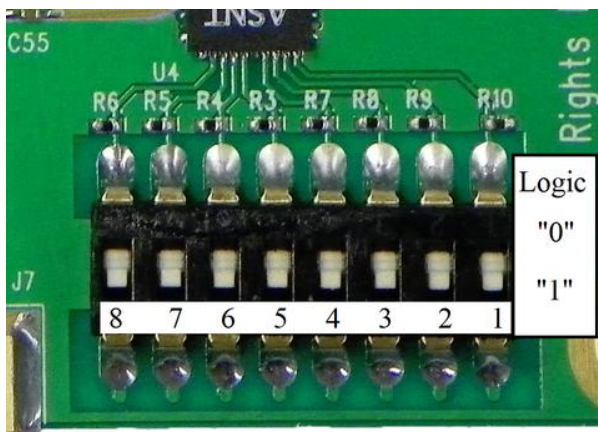

DIVIDE-BY-2 SWITCH

Switching the divide-by-2 switch to the position shown below (Div/2) will override any divide ratio that is currently set on the divide ratio control and output a divide-by-2. Switching the divide-by-2 switch to the position below (Div/4-1024) will turn on the divide ratio control.

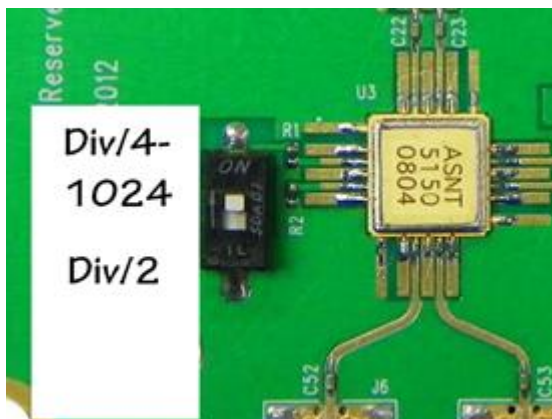



ABSOLUTE MAXIMUM RATINGS

Caution: Exceeding the absolute maximum ratings shown in [Table 2](#) may cause damage to this product and/or lead to reduced reliability. Functional performance is specified over the recommended operating conditions for power supply and temperature only. AC and DC device characteristics at or beyond the absolute maximum ratings are not assumed or implied. All min and max voltage limits are referenced to ground.

Table 2. Absolute Maximum Ratings

Parameter	Min	Max	Units
Supply Voltage (vee)		+3.6	V
Power Consumption		3.6	W
RF Input Voltage Swing (SE)		1.0	V
Case Temperature		+90	°C
Storage Temperature	-40	+100	°C
Operational Humidity	10	98	%
Storage Humidity	10	98	%

TERMINAL FUNCTIONS

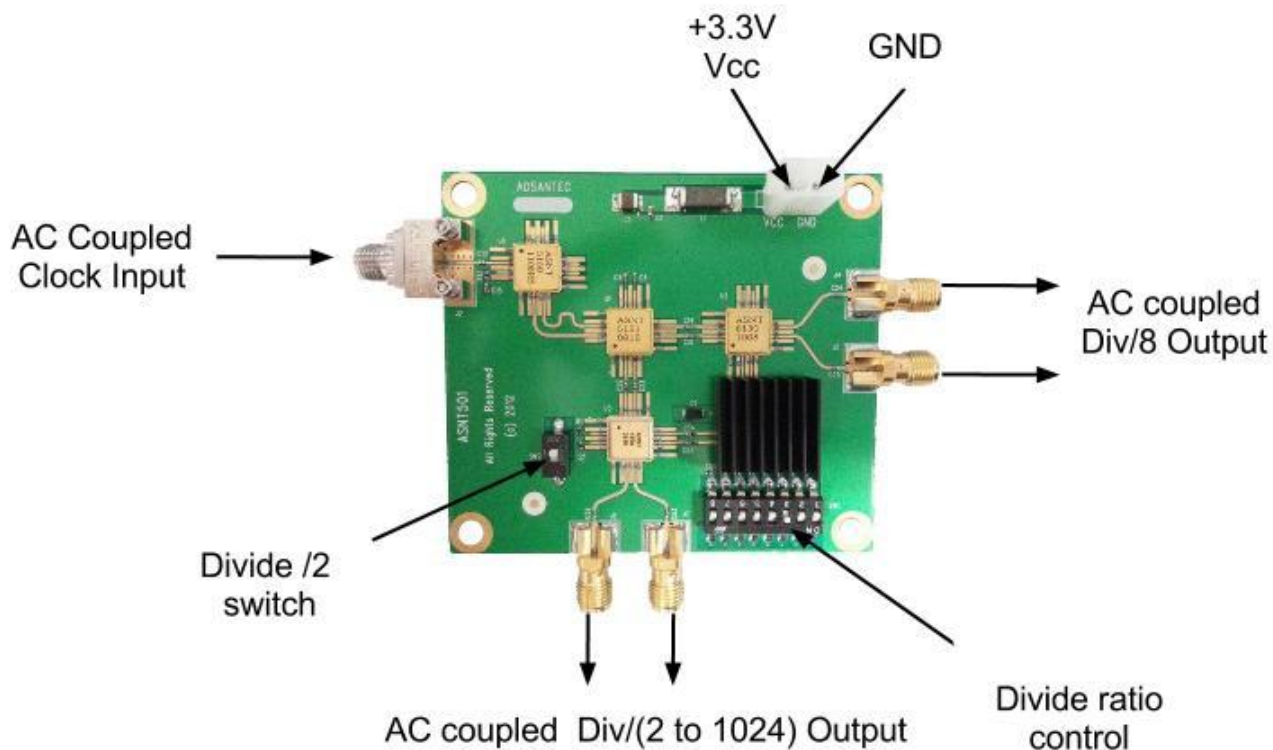



ELECTRICAL CHARACTERISTICS

PARAMETER	MIN	TYP	MAX	UNIT	COMMENTS
General Parameters					
V _{EE}	0			V	External ground
V _{CC}	3.1	3.3	3.5	V	
I _{VCC}	1100			mA	
Power	3.6			W	
Operating Temperature	-25	50	85	°C	
Clock Input					
Frequency	2.0E-5		41	GHz	
Single-ended Swing	50	400	1000	mV _{PP}	
Common Mode Level	V _{CC} -0.8	V _{CC} -0.2	V _{CC}	V	
Duty Cycle	40	50	60	%	Range of input tolerance
Output (Div/8)					
Frequency	2.0E-5		5.125	GHz	
Single-ended Swing	380	400	420	mV _{PP}	
Rise/Fall Time	10	12	14	ps	20% to 80%
Additive Jitter	<1			ps	Peak-to-Peak
Duty Cycle	45	50	55	%	For clock signal
Output (2-to-1024)					
Frequency	2.0E-5		20.5	GHz	
Single-ended Swing	380	400	420	mV _{PP}	
Rise/Fall Time	10	12	14	ps	20% to 80%
Additive Jitter	<1			ps	Peak-to-Peak
Duty Cycle	45	50	55	%	For clock signal



REVISION HISTORY

Revision	Date	Changes
1.6.2	07-2019	Updated Letterhead
1.6.1	04-2019	Reverted Previous Change Added P/N to connectors' description
1.5.1	07-2018	Updated Input Connector to SV Microwave
1.4.1	09-2015	Corrected Power Consumption Information Corrected Divide-by-2/4-1024 Picture
1.3.1	05-2013	Revised title Revised description Revised applications Revised divide ratio control
1.2.1	03-2013	Updated maximum operating frequency Updated functional block Updated format Added maximum ratings
1.1.1	03-2013	Updated pictures Update PN for connectors
1.0.1	07-2012	Revised formatting
1.0	04-2012	Initial release