

NIR-MPX series

1000 nm band Phase Modulators

Modulator

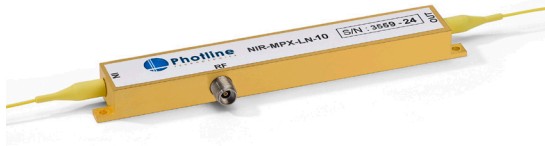

The NIR-MPX series are phase modulators especially designed to operate in the 1000 nm wavelength band. They are available with various modulation bandwidth, from low frequency to 10 GHz and beyond.

Like all Photline Technologies Near InfraRed (NIR) modulators, the NIR-MPX series use a proton exchanged based waveguide process that confers them an unparalleled stability and a high photo-refractive threshold.

Features

- High optical power : 100 mW
- High Bandwidth > 10 GHz
- High stability
- Low V_{π}
- Low insertion loss

Applications

- Interferometric based sensors
- Spectral broadening
- Frequency shifting

Options

- Hermetic sealing
- 20 GHz version
- 800 nm, 1300 nm band versions

Related equipments

- Match RF amplifiers
- NIR-MX-LN intensity modulators

NIR-MPX-LN-0.1 series Performance Highlights

Parameter	Min	Typ	Max	Unit
Operating wavelength	980	1060	1150	nm
Electro-optical bandwidth	-	150	-	MHz
V_{π} RF @50 kHz	-	2.5	-	V
Insertion loss	-	3.5	-	dB

Specifications given at 25 °C, 1060 nm

NIR-MPX-LN-05 series Performance Highlights

Parameter	Min	Typ	Max	Unit
Operating wavelength	980	1060	1150	nm
Electro-optical bandwidth	-	5	-	GHz
V_{π} RF @50 kHz	-	6	-	V
Insertion loss	-	3.5	-	dB

Specifications given at 25 °C, 1060 nm

NIR-MPX-LN-10 series Performance Highlights

Parameter	Min	Typ	Max	Unit
Operating wavelength	980	1060	1150	nm
Electro-optical bandwidth	-	12	-	GHz
V_{π} RF @50 kHz	-	8	-	V
Insertion loss	-	3.5	-	dB

Specifications given at 25 °C, 1060 nm

NIR-MPX series

1000 nm band Phase Modulators



Modulator

NIR-MPX-LN-0.1

150 MHz Phase modulator

Electrical Characteristics

Parameter	Symbol	Condition	Min	Typ	Max	Unit
Electro-optic bandwidth	S_{21}	RF electrodes	-	150	-	MHz
V_{π} RF @50 kHz	V_{π} RF _{50 kHz}	RF electrodes	-	2.5	3	V
RF input impedance	Z_{in-RF}	-	-	10 000	-	Ω

Optical Characteristics

All specifications given at 25 °C, 1060 nm, unless differently specified

Parameter	Symbol	Condition	Min	Typ	Max	Unit
Crystal	-	-	Lithium Niobate X-Cut Y-Prop			
Waveguide process	-	-	Proton exchange			
Operating wavelength	λ	-	980	1060	1150	nm
Insertion loss	IL	Without connectors	-	3.5	4.5	dB
Optical return loss	ORL	-	-40	-45	-	dB

Absolute Maximum Ratings

Stresses in excess of the absolute maximum ratings can cause permanent damage to the device. These are absolute stress ratings only. Functional operation of the device is not implied at these or any other conditions in excess of those given in the operational sections of the data sheet. Exposure to absolute maximum ratings for extended periods can adversely affect device reliability.

Parameter	Symbol	Min	Max	Unit
Modulation voltage range	EV_{in}	-20	20	V
Optical input power	OP_{in}	-	20	dBm
Operating temperature	OT	0	+70	°C
Storage temperature	ST	-40	+85	°C

NIR-MPX-LN-05
5 GHz Phase modulator

Electrical Characteristics

Parameter	Symbol	Condition	Min	Typ	Max	Unit
Electro-optic bandwidth	S_{21}	RF electrodes, from 2 GHz	4	5	-	GHz
Ripple S_{21}	ΔS_{21}	RF electrodes	-	0.5	1	dB
Electrical return loss	ES_{11}	RF electrodes	-	-12	-10	dB
V_{π} RF @50 kHz	V_{π} RF _{50 kHz}	RF electrodes	-	6	7	V
RF input impedance	Z_{in-RF}	-	-	40	-	Ω

Optical Characteristics All specifications given at 25 °C, 1060 nm, unless differently specified

Parameter	Symbol	Condition	Min	Typ	Max	Unit
Crystal	-	-	Lithium Niobate X-Cut Y-Prop			
Waveguide process	-	-	Proton exchange			
Operating wavelength	λ	-	980	1060	1150	nm
Insertion loss	IL	Without connectors	-	3.5	4.5	dB
Optical return loss	ORL	-	-40	-45	-	dB

Absolute Maximum Ratings

Stresses in excess of the absolute maximum ratings can cause permanent damage to the device. These are absolute stress ratings only. Functional operation of the device is not implied at these or any other conditions in excess of those given in the operational sections of the data sheet. Exposure to absolute maximum ratings for extended periods can adversely affect device reliability.

Parameter	Symbol	Min	Max	Unit
RF input power	EP_{in}	-	28	dBm
Optical input power	OP_{in}	-	20	dBm
Operating temperature	OT	0	+70	°C
Storage temperature	ST	-40	+85	°C

NIR-MPX-LN-10
10 GHz Phase modulator

Electrical Characteristics

Parameter	Symbol	Condition	Min	Typ	Max	Unit
Electro-optic bandwidth	S_{21}	RF electrodes, from 2 GHz	10	12	-	GHz
Ripple S_{21}	ΔS_{21}	RF electrodes	-	0.5	1	dB
Electrical return loss	ES_{11}	RF electrodes	-	-12	-10	dB
V_{π} RF @50 kHz	$V_{\pi \text{ RF } 50 \text{ kHz}}$	RF electrodes	-	8	9	V
RF input impedance	Z_{in-RF}	-	-	40	-	Ω

Optical Characteristics All specifications given at 25 °C, 1060 nm, unless differently specified

Parameter	Symbol	Condition	Min	Typ	Max	Unit
Crystal	-	-	Lithium Niobate X-Cut Y-Prop			
Waveguide process	-	-	Proton exchange			
Operating wavelength	λ	-	980	1060	1150	nm
Insertion loss	IL	Without connectors	-	3.5	4.5	dB
Optical return loss	ORL	-	-40	-45	-	dB

Absolute Maximum Ratings

Stresses in excess of the absolute maximum ratings can cause permanent damage to the device. These are absolute stress ratings only. Functional operation of the device is not implied at these or any other conditions in excess of those given in the operational sections of the data sheet. Exposure to absolute maximum ratings for extended periods can adversely affect device reliability.

Parameter	Symbol	Min	Max	Unit
RF input power	EP_{in}	-	28	dBm
Optical input power	OP_{in}	-	20	dBm
Operating temperature	OT	0	+70	°C
Storage temperature	ST	-40	+85	°C

NIR-MPX series
1000 nm band Phase Modulators

Modulator

Mechanical Diagram and Pinout All measurements in mm

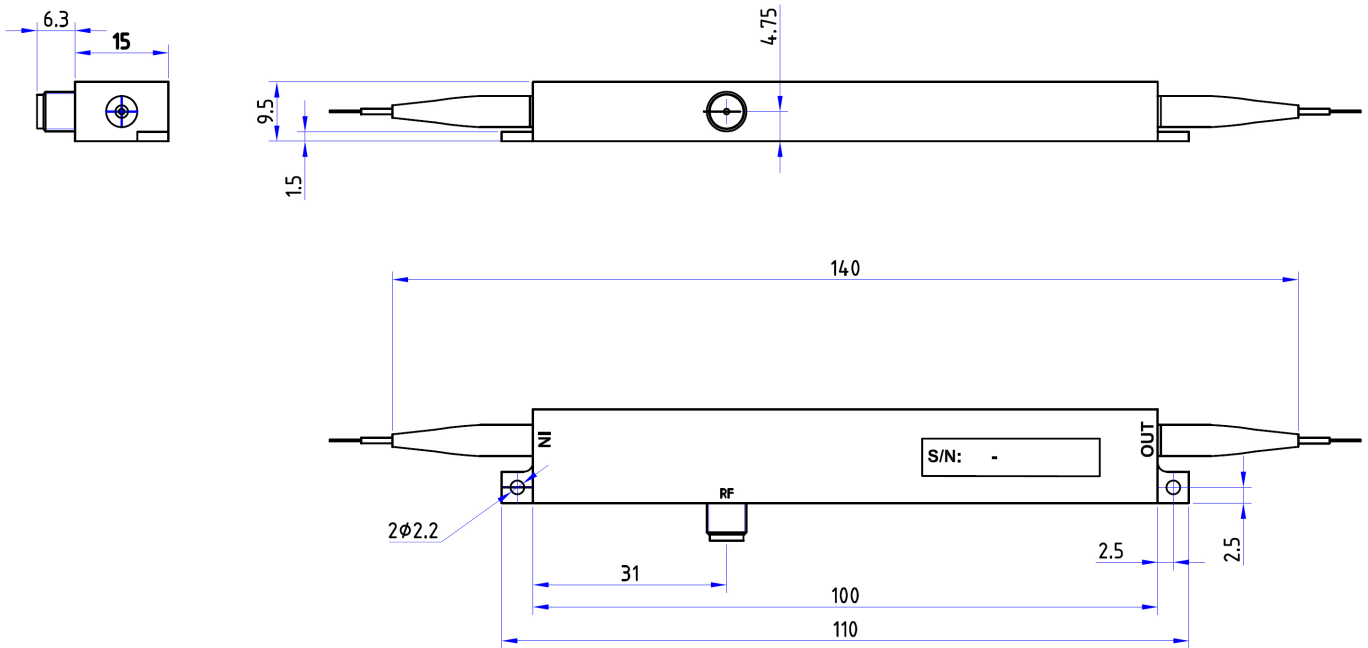

Port	Function	Note
IN	Optical input port	Polarization maintaining fiber 980 nm, Corning 98-U25A, Length 1.5 meter. Buffer diameter 900 μm
OUT	Optical output port	Polarization maintaining fiber 980 nm, Corning 98-U25A, Length 1.5 meter. Buffer diameter 900 μm
RF	RF input port	Wiltron female K

Ordering information

NIR-MPX-LN-XX-Y-Z-AB-CD

XX = Bandwidth : 0.1 150 MHz 05 5 GHz 10 10 GHz

Y = Input fiber : P Polarisation maintaining S Standard single mode

Z = Input fiber : P Polarisation maintaining S Standard single mode

AB = Output connector : 00 bare fiber FA FC/APC FC FC/SPC

CD = Output connector : 00 bare fiber FA FC/APC FC FC/SPC

NIR-MPX series
1000 nm band Phase Modulators

Modulator

Related equipments & Examples of application

Single Side Band with Carrier Suppressed

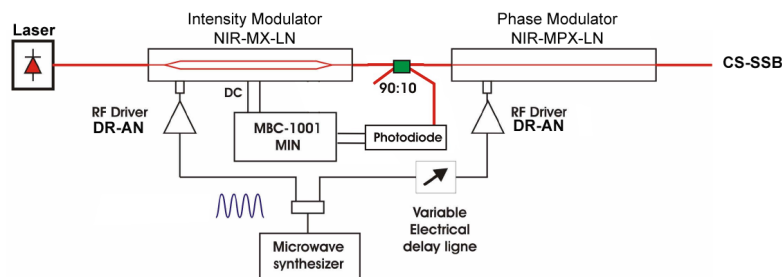

Efficient Single Side Band modulation and Carrier Suppression can be achieved by using a combination of Intensity and Phase modulators properly driven with DR-AN analog RF amplifiers.

Side Bands Generation / Frequency Shifting

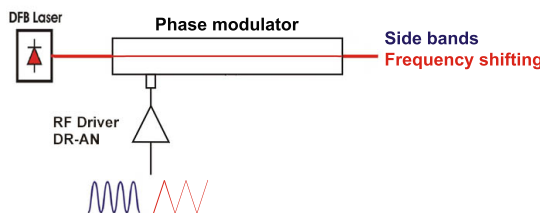

DR-AN series amplifiers are high performance analog drivers for NIR-MPX-LN-05 and NIR-MPX-LN-10.

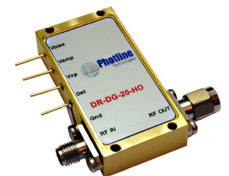

1000 nm ModBoxes are custom designed Modulation Units and Transmitters. They incorporate a complete and dedicated modulation stage with power supply and control electronics and optional laser source and receiver. ModBoxes can be tailored to accommodate a broad variety of applications : pulse generation, pulse picking, spectral broadening, analog modulation, digital communication....

ABOUT US

Photline Technologies is a provider of Fiber Optics Modulation Solutions based on the company LiNbO3 modulators and high-speed electronics modules. Photline Technologies offers high speed and high data rate modulation solutions for the telecommunication industry and the defense, aerospace, instruments and sensors markets. The products offered by the company include : comprehensive range of intensity and phase modulators (800 nm, 1060 nm, 1300 nm, 1550 nm), RF drivers and modules, transmitters and modulation units.

Photline Technologies
phone : +33 (0) 381 853 180
fax : +33 (0) 381 811 557
16, rue Auguste Jouchoux
F-25 000 Besançon

Photline Technologies reserves the right to change, at any time and without notice, the specifications, design, function or form of its products described herein. All statements, specification, technical information related to the products herein are given in good faith and based upon information believed to be reliable and accurate at the moment of printing. However the accuracy and completeness thereof is not guaranteed. No liability is assumed for any inaccuracies and as a result of use of the products. The user must validate all parameters for each application before use and he assumes all risks in connection with the use of the products.

V1, PT-Q1-2010